

Using SOP8/MSOP8 package 1A Linear Li-Ion Battery Charger

General Description

The 1056 is a complete constant current & constant voltage linear charger for single cell lithium-ion batteries. Its SOP/MSOP package and low external component count make the 1056 ideally suited for portable applications. Furthermore, the 1056 is specifically designed to work within USB power specifications. No external sense resistor is needed, and no blocking diode is required due to the internal MOSFET architecture. Thermal feedback regulates the charge current to limit the die temperature during high power operation or high ambient temperature. The charge voltage is fixed at 4.2V, and the charge current can be programmed externally with a single resistor. The 1056 automatically terminates the charge cycle when the charge current drops to 1/10th the programmed value after the final float voltage is reached. When the input supply (wall adapter or USB supply) is removed, the 1056 automatically enters a low current state, dropping the battery drain current to less than 2uA. The 1056 can be put into shutdown mode, reducing the supply current to 50uA. Other features include Battery temperature monitor, under-voltage lockout, automatic recharge and two status pins to indicate charge and charge termination.

Applications

- Cellular Telephones, PDAs, MP3 /MP4 Players
- Charging Docks and Cradles
- Bluetooth 、GPS Applications

Features

- Programmable Charge Current Up to 1000mA
- No MOSFET, Sense Resistor or Blocking Diode Required
- Complete Linear Charger in SOP/MSOP Package for single Cell Lithium-Ion Batteries
- Constant-Current/Constant-Voltage Operation with Thermal Regulation to Maximize Charge Rate Without Risk of Overheating
- Charges Single Cell Li-Ion Batteries Directly from USB Port
- Preset 4.2V Charge Voltage with $\pm 1\%$ Accuracy
- Charge Current Monitor Output for Gas Gauging
- Automatic Recharge
- Charge state pairs of output, no battery and fault status display
- C/10 Charge Termination
- 50uA Supply Current in Shutdown
- 2.9V Trickle Charge Threshold
- Soft-Start Limits Inrush Current
- Battery temperature monitoring function
- Available in SOP8-PP/ MSOP8-PP Package

Package

SOP8-PP/MSOP8-PP

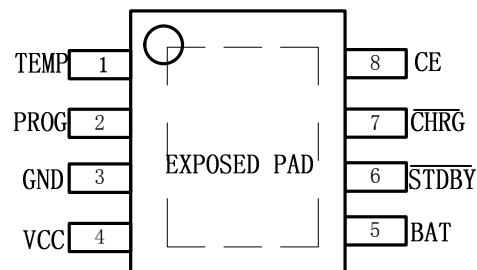

Typical Application Circuit

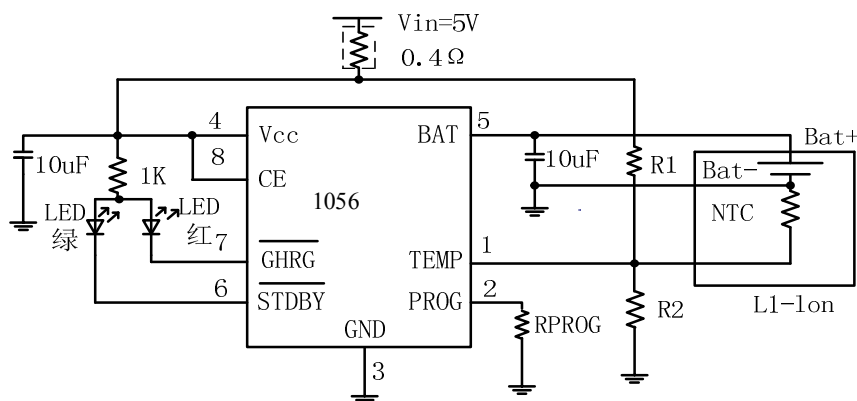

Figure 1. Basic Application Circuit with 1056

Pin Description

Pin No.	Pin Name	Pin Function
1	TEMP	Battery temperature detection input.
2	PROG	Charge Current Program, Charge Current Monitor and Shutdown Pin.
3	GND	Ground.
4	VCC	Positive Input Supply Voltage.
5	BAT	Charge Current Output.
6	STDBY	The completion of battery charging instructions side.
7	CHRG	Open-Drain Charge Status Output.
8	CE	Chip enable input.

Functional Block Diagram

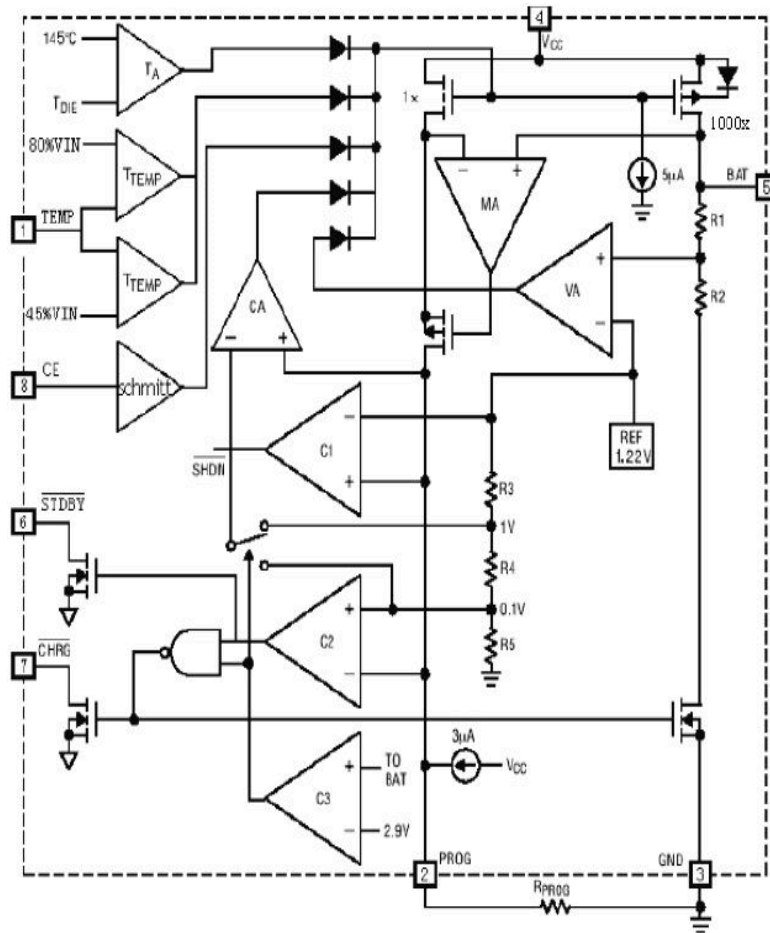

Figure 2. Block Diagram

Absolute Maximum Ratings

PARAMETER	SYMBOL	MAXIMUM RATING	UNIT
Input Supply Voltage	V _{cc}	V _{SS} -0.3~V _{SS} +6.0	V
PROG pin Voltage	V _{prog}	V _{SS} -0.3~V _{CC} +0.3	
BAT pin Voltage	V _{bat}	V _{SS} -0.3~6.0	
CHAG pin Voltage	V _{chrg}	V _{SS} -0.3~V _{SS} +6.0	
BAT pin Current	I _{bat}	1400	mA
PROG pin Current	I _{prog}	1400	uA
Operating Ambient Temperature	T _{opa}	-40~+85	°C
Storage Temperature	T _{str}	-65~+125	
Lead Temperature (Soldering, 10s)		260	

Caution: The absolute maximum ratings are rated values exceeding which the product could suffer physical damage. These values must therefore not be exceeded under any conditions.

Electrical Characteristics

Parameter	Symbol	CONDITION	MIN	TYP	MAX	UNIT
Input supply voltage	V _{cc}		4.25		5.5	V
Input supply current	I _{cc}	Charge mode, R _{PROG} =10K		350	2000	uA
		Standby mode		150	500	uA
		Shutdown mode(R _{PROG} not connected, V _{cc} <V _{bat} or V _{cc} <V _{uv})		50	100	uA
Regulated Output Voltage	V _{float}	0°C≤T _A ≤85°C, I _{BAT} =	4.158	4.2	4.242	V
BAT pin Current	I _{bat}	R _{PROG} =2k, Current mode	450	500	550	mA
		R _{PROG} =1k, Current mode	900	1000	1100	mA
		Standby mode, V _{bat} =4.2V	0	-2.5	-6	uA
		Shutdown mode		± 1	± 2.5	uA
		Sleep mode, V _{cc} =0V		0.3	± 2.5	uA
Trickle charge current	I _{trikl}	V _{bat} <V _{trikl} , R _{prog} =1k	90	100	110	mA
Trickle charge Threshold Voltage	V _{trikl}	R _{PROG} =10K, V _{bat} Rising	2.8	2.9	3.0	V
Trickle voltage hysteresis voltage	V _{trhys}	R _{PROG} =1k	60	80	110	mV
V _{cc} Undervoltage lockout Threshold	V _{uv}	From V _{cc} low to high	3.7	3.8	3.93	V
V _{cc} undervoltage lockout hysteresis	V _{uvhys}		150	200	300	mV
V _{cc} -V _{bat} Lockout Threshold voltage	V _{asd}	V _{cc} from low to high	50	100	140	mV
		V _{cc} from high to low	5	40	50	mV
C/10 Termination Current Threshold	I _{term}	R _{PROG} =1k	0.085	0.1	0.115	mA/mA
		R _{PROG} =2k	0.085	0.1	0.115	mA/mA
PROG pin Voltage	V _{prog}	R _{PROG} =1k, Current mode	0.93	1.0	1.07	V

CHRG pin Output low voltage	Vchrg	Ichrg=5mA		0.35	0.6	V
STDBY pin Output low voltage	Vstdby	Istdby=5mA		0.35	0.6	V
Recharge Battery threshold Voltage	ΔV_{recg}	$V_{FLOAT} - V_{RECHRG}$		100	200	mV
CE high voltage	Vce-h		1.2			V
CE low voltage	Vce-l		.		0.6	V
TEMP pin voltage of the high-end flip	Vtemp-h			80	82	%Vcc
TEMP pin voltage of the low-end flip	Vtemp-l		43	45		%Vcc
Limited temperature patterns in the junction temperature	Tlim			145		°C

Typical Performance Characteristics

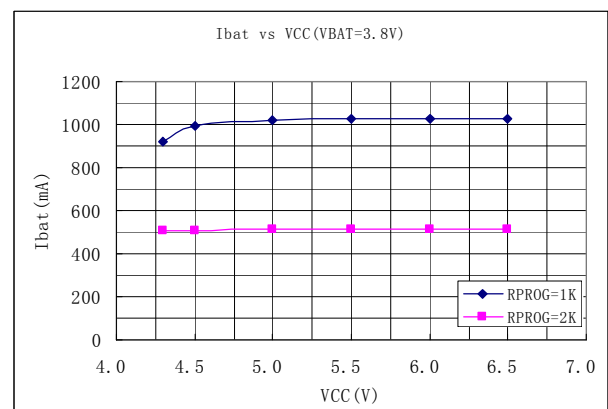
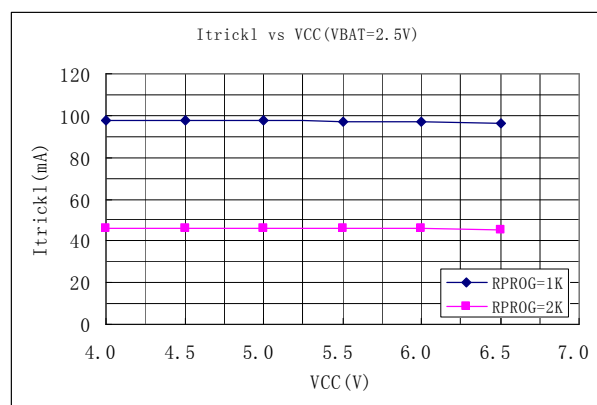
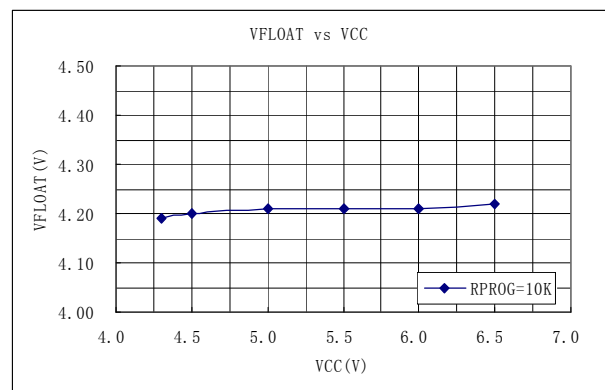
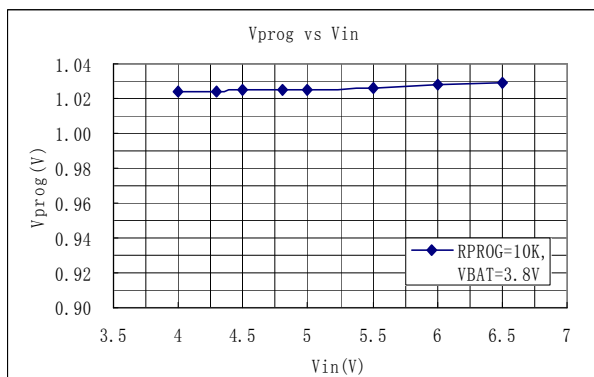

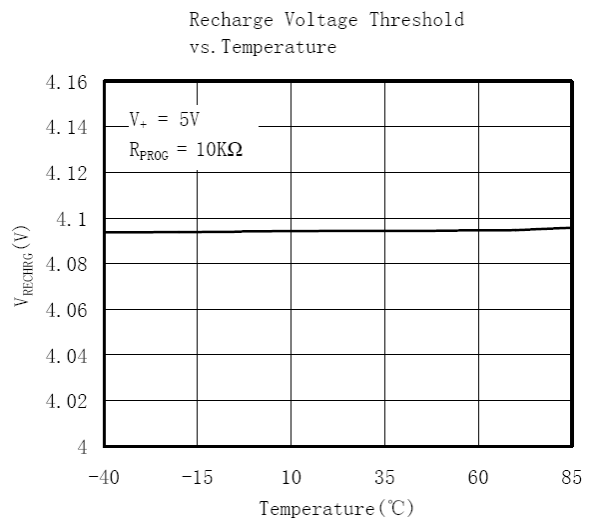
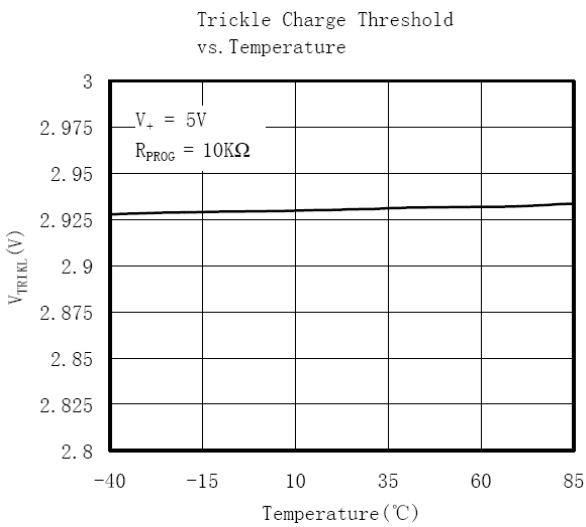
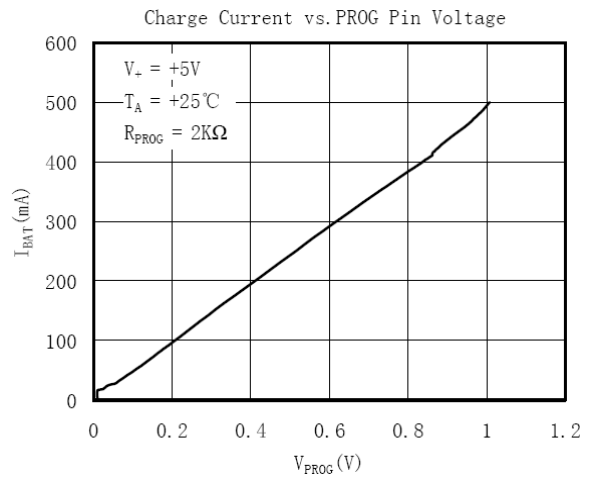
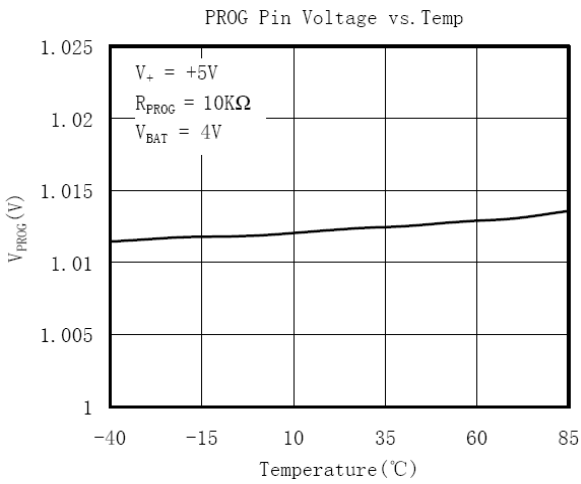
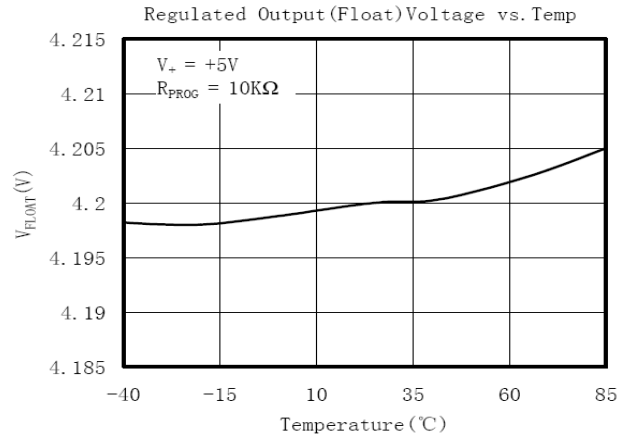
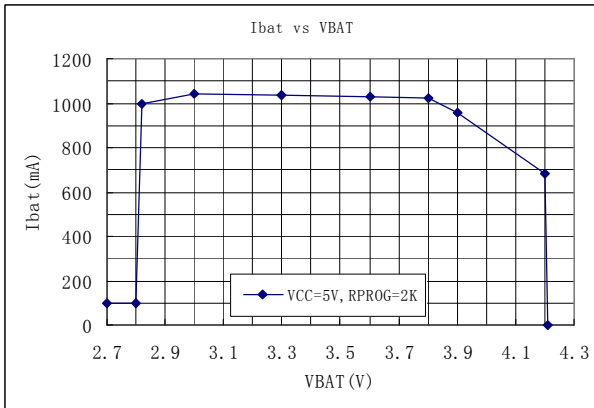

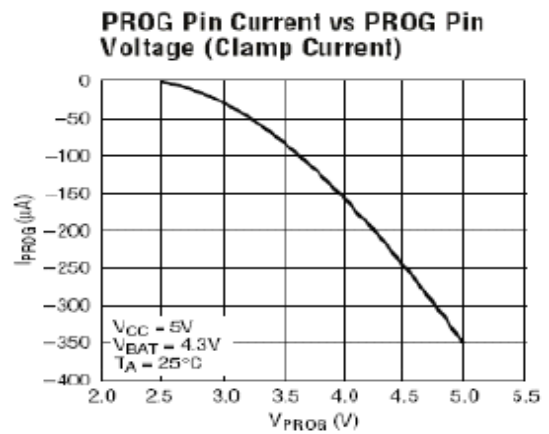
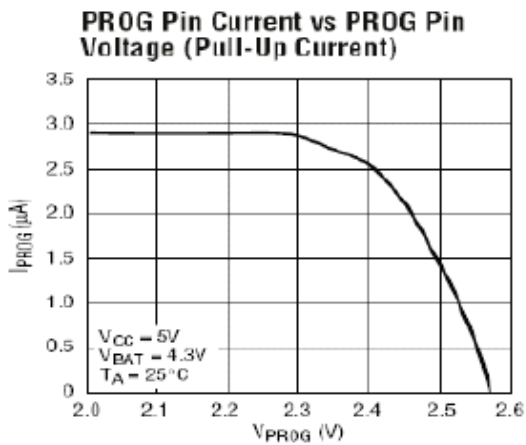
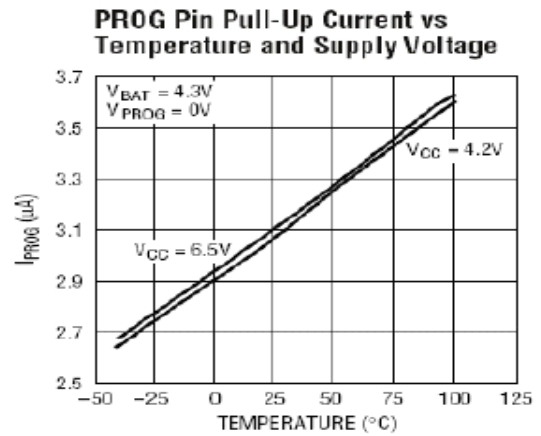
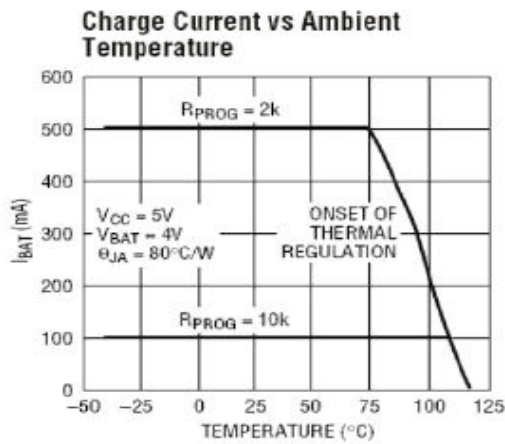

Ordering Information

Part Number	Top Mark	Package
1056	1056 XXXX ¹	SOP8-PP
1056IM8P	1056 XXXX ¹	MSOP8-PP

1. XXXX= date code

Pin Function

TEMP (Pin 1): Battery temperature detection input. TEMP pin to receive the battery NTC sensor output. If the TEMP pin voltage is less than the input voltage is greater than 45% or 80% of the input voltage means the battery temperature is too low or too high, then the charge has been suspended.

If the TEMP direct access GND, battery temperature detection canceled, the other charged and functioning properly.

PROG (Pin 2): Charge Current Program, Charge Current Monitor and Shutdown Pin. The charge current is programmed by connecting a 1% resistor, R_{PROG}, to ground. When charging in constant-current mode, this pin serves to 1V. In all modes, the voltage on this pin can be used to measure the charge current using the following formula:
$$I_{BAT} = (V_{PROG}/R_{PROG}) \cdot 1000.$$

The PROG pin can also be used to shut down the charger. Disconnecting the program resistor from ground allows a 3uA current to pull the PROG pin high. When it reaches the 1.21V shutdown threshold voltage, the charger enters shutdown mode, charging stops and the input supply current drops to 50uA. This pin is also clamped to approximately 2.4V. Driving this pin to voltages beyond the clamp voltage will draw currents as high as 1.5mA. Reconnecting R_{PROG} to ground will return the charger to normal operation.

GND (Pin 3): Ground.

VCC (Pin 4): Positive Input Supply Voltage. Provides power to the charger, VCC can range from 4.25V to 6.5V and should be bypassed with at least a 10uF capacitor. When VCC drops to within 30mV of the BAT pin voltage, the 1056 enters shutdown mode, dropping I_{BAT} to less than 2uA.

BAT (Pin 5): Charge Current Output. Provides charge current to the battery and regulates the final float voltage to 4.2V. An internal precision resistor divider from this pin sets the float voltage which is disconnected in shutdown mode.

STDBY (Pin 6): The completion of battery charging instructions side. When the battery charge is complete, STDBY pulled low by internal switches, indicating the completion of charging. In addition, STDBY pin will be in a high-impedance state.

CHRG (Pin 7): Open-Drain Charge Status Output. When the battery is charging, the CHRG pin is pulled low by an internal N-channel MOSFET. When the charge cycle is completed, CHRG pin will be in a high-impedance state.

CE (Pin 8): Chip enable input. High input level would 1056 is in normal working condition; low input level so that 1056 is prohibited charging status. CE pin can be TTL or CMOS level-level driver.

TEMP 配置参考：

不使用电池温度检测时,将NTC直接接地。

可以配置下：R1=6.2K R2=100K

00度时 R2的有效值为 24.3K TEMP=79.6% 接近低温关闭

25度时 R2的有效值为 9.09K TEMP=59%

40度时 R2的有效值为 5.03K TEMP=46.1% 接近关闭温度

42度时 R2的有效值为 4.67K TEMP=42.96% 关闭输出

此NTC保证为25摄氏度时10K阻值。 R2有效值：R2与NTC并联的有效阻值 R1和R2为精密电阻

Package Information

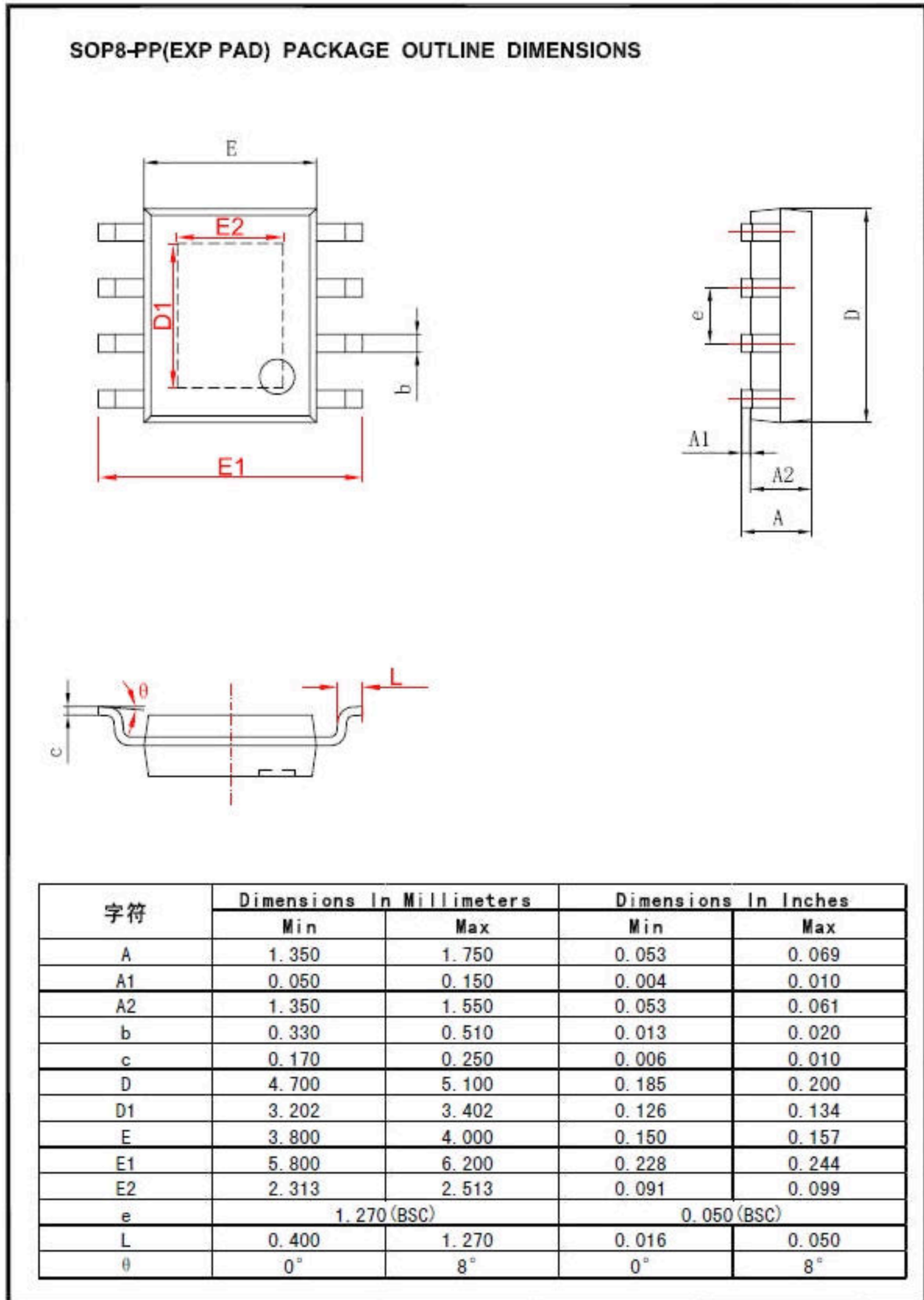

MSOP8/PP PACKAGE OUTLINE DIMENSIONS

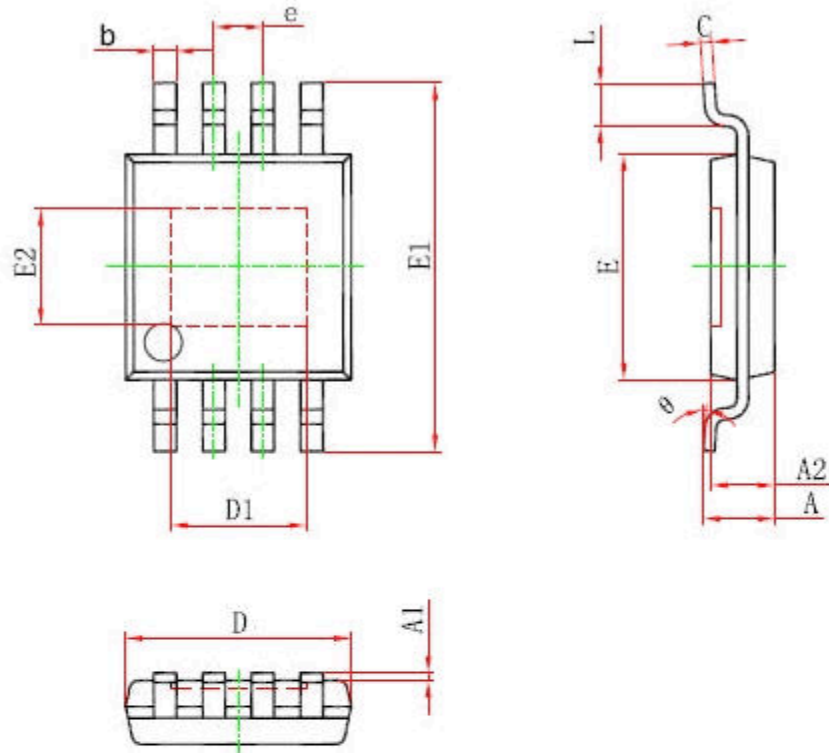

Symbol	Dimensions In Millimeters		Dimensions In Inches	
	Min	Max	Min	Max
A	0.820	1.100	0.032	0.043
A1	0.020	0.150	0.001	0.006
A2	0.750	0.950	0.030	0.037
b	0.250	0.380	0.010	0.015
c	0.090	0.230	0.004	0.009
D	2.900	3.100	0.114	0.122
D1	1.700	1.900	0.067	0.075
e	0.65 (BSC)		0.026 (BSC)	
E	2.900	3.100	0.114	0.122
E1	4.750	5.050	0.187	0.199
E2	1.450	1.650	0.057	0.065
L	0.400	0.800	0.016	0.031
θ	0°	6°	0°	6°

